



SmartAir
Balance Your Climate

THE PM VFD MOVABLE FAN





Variable speed



Energy efficient



Natural wind



Low noise



Compact structure



Easy to move

SmartAir Jiant Industrial Portable Fan is a new product specially developed for improving the comfort of working environment. Self-designed variable frequency speed control, high efficiency and energy saving permanent magnet external rotor motor drive. It has the advantages of low noise, small volume, light weight, compact structure and beautiful appearance.

SmartAir Jiant Industrial Portable Fan

Widely used in fitness center, outdoor wedding venues, industrial factory, logistics warehousing, waiting room, exhibition hall, physical education hall and other large space places, as a new type of ceiling fan space ventilation, personnel cooling. It can push a large amount of airflow to the ground, forming a certain height of the moving airflow layer, thus contributing to the overall air circulation; Like the natural breeze system, enjoy the intimate experience of natural wind.



Fitness Centers



Outdoor Weddings



Industrial Plants



Logistics and Storage



Waiting Rooms



Exhibition Halls



Gymnasiums



Large Shopping Malls



NATURAL THREE-DIMENSIONAL AIR SUPPLY ENHANCE HUMAN COMFORT



1~2m

Blade diameter



1m~6m/s

Wind speed range



28m

Maximum blowing distance



SmartAir Jiant Industrial Portable Fan, with unique wing design, straight blade diameter from 1~2m, adopting the principle of aerodynamics and advanced technology manufacturing blades wing, formed by strong air agitation ability of circulation flow field, produce like the breeze system of nature, the body will feel three-dimensional wind from all directions, increased sweat evaporation area, increase your comfort level.

At the same time avoid the use of traditional high-speed fan in the direction of the wind all year round, causing a variety of human health problems, greatly improve the comfort of the environment. SmartAir Jiant Industrial Portable Fans can be combined with the actual needs of different occasions to adjust the wind volume, the wind speed in the range of 1m-6m /s can be arbitrarily adjusted. In the open space, the industrial energy-saving mobile fan's maximum blowing distance is 28 meters.

PERMANENT MAGNET SYNCHRONOUS MOTOR

FEATURES:

- Without rotor losses
- High efficiency and precision
- Large power factor
- Improve grid operating environment.
- Frequency modulation width (0~200HZ)
- Small size and light weight
- Saving energy and high efficient



STREAMLINED FAN BLADE + ENERGY SAVING TAIL

FAN BLADE:

It is made of aluminum and magnesium alloy extruded and stretched, and has the advantages of high strength, good toughness, light weight, long life and safe operation. The fan blade surface is treated with T5+ bright surface oxidation treatment, which enhances the corrosion and oxidation resistance of the fan blade and can cope with special environmental operations.

Airfoil Internal Reinforcement Structure



TAIL

When the fan blade is running, the air will generate vortex at the end of the aerofoil fan blade. The tail wing can eliminate this part of energy loss, stabilize the fan operation, and make the air flow more consistent with the aerodynamic principle.

SMART CONTROL SYSTEM



- The system is no position vector control, anti - electromagnetic interference, anti - radiation, small size, light weight, beautiful appearance.
- System function is simple, 4 buttons easy to operation (start, stop, speed up, slow down).
- System with overvoltage, undervoltage, voltage loss regulation, current, lack of phase, overload, collision, overheating, lightning, abnormal protection.

TECHNICAL DATA

Model	Diameter (m)	Voltage (v)	Frequency (Hz)	Power (kW)	Rotating Speed (rpm)	Air speed (m/s)	Airflow (m3/h)	Weight (kg)	Noise (dB)	Coverage area (m2)
JHVF-P200	2	220/380	50/60	1	≤300	1-5.5	80000	122	39	260
JHVF-P200-T	2	220/380	50/60	1	≤300	1-5.5	52000	211	40	260
JHVF-P150	1.5	220/380	50/60	0.75	≤420	1-6.5	55000	93	39	150
JHVF-P120	1	220/380	50/60	0.55	≤600	1-7	30000	73	39	80

PLACEMENT ENVIRONMENT

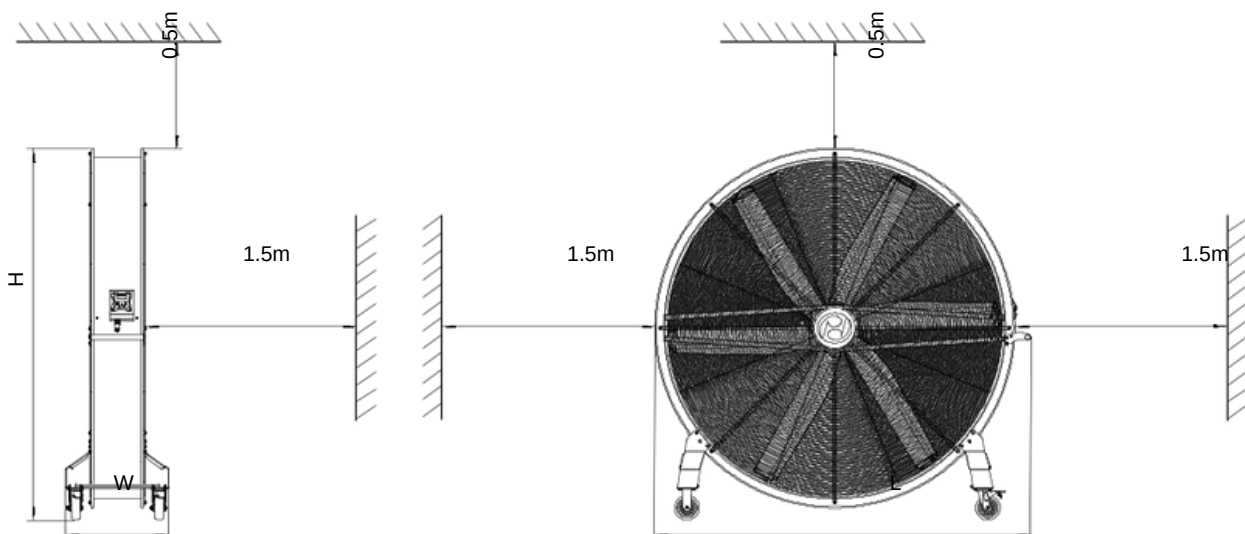

INSTALLATION DATA

Model	L (cm)	W (cm)	H (cm)
JHVF-P200	222	61	219
JHVF-P150	172	60	169
JHVF-P120	131	56	146

SmartAir Jiant Industrial Portable Fan



SmartAir
Balance Your Climate

SmartAir LTD
Tel: +972 54-660-7676
Company Number 516362498
www.smrt-air.com
sales@smrt-air.com

